

MECHANICAL DATA

Dimensions in mm (inches)

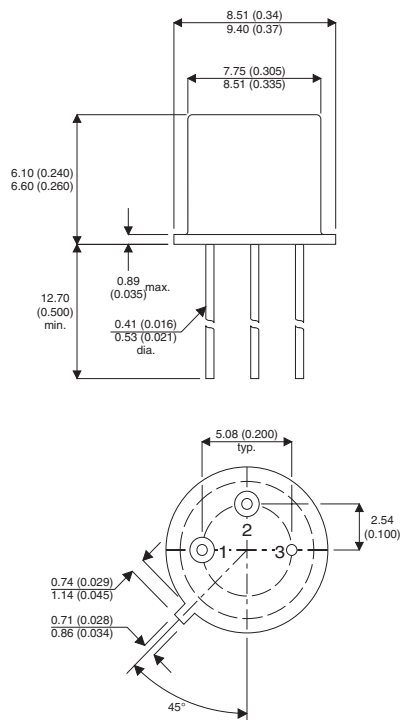

TO-39 (TO-205AD) METAL PACKAGE)

Underside View

PIN 1 – Emitter PIN 2 – Base PAD 3 – Collector

**BIPOLAR NPN
SILICON TRANSISTOR**

FEATURES

- GENERAL PURPOSE NPN TRANSISTOR
- HERMETICALLY SEALED METAL PACKAGE
- JAN LEVEL SCREENING OPTIONS
- CECC LEVEL SCREENING OPTIONS

ABSOLUTE MAXIMUM RATINGS ($T_{case} = 25^{\circ}C$ unless otherwise stated)

V_{CBO}	Collector – Base Voltage	180V
V_{CEO}	Collector – Emitter Voltage	140V
V_{EBO}	Emitter – Base Voltage	6V
I_C	Continuous Collector Current	2.5A
P_{tot}	Power Dissipation	10W
$R_{\theta JC}$	Thermal Resistance Junction to Case	15°C/W
T_J, T_{stg}	Operating and Storage Temperature	-55 to 175°C

Semelab Plc reserves the right to change test conditions, parameter limits and package dimensions without notice. Information furnished by Semelab is believed to be both accurate and reliable at the time of going to press. However Semelab assumes no responsibility for any errors or omissions discovered in its use. Semelab encourages customers to verify that datasheets are current before placing orders.

ELECTRICAL CHARACTERISTICS ($T_C = 25^\circ\text{C}$ unless otherwise stated)

Parameter	Test Conditions	Min.	Typ.	Max.	Unit
$V_{(BR)CBO}$ Collector – Base Breakdown Voltage	$I_C = 100\mu\text{A}$ $I_E = 0$	180			V
$V_{(BR)CEO}$ Collector – Emitter Breakdown Voltage	$I_C = 10\text{mA}$ $I_B = 0$	140			
$V_{(BR)EBO}$ Emitter – Base Breakdown Voltage	$I_E = 100\mu\text{A}$ $I_C = 0$	6			
I_{CBO} Collector – Base Cut-off Current	$V_{CB} = 175\text{V}$ $I_E = 0$			100	μA
I_{CEO} Collector – Emitter Cut-off Current	$V_{CE} = 10\text{V}$ $I_B = 0$			10	mA
$V_{CE(sat)}$ Collector – Emitter Saturation Voltage	$I_C = 500\text{mA}$ $I_B = 50\text{mA}$			0.6	V
V_{BE} Base – Emitter Voltage	$I_C = 1\text{A}$ $V_{CE} = 10\text{V}$			1.1	
h_{FE} Static Forward Current Transfer Ratio	$I_C = 1\text{A}$ $V_{CE} = 10\text{V}$	20		140	—

Semelab Plc reserves the right to change test conditions, parameter limits and package dimensions without notice. Information furnished by Semelab is believed to be both accurate and reliable at the time of going to press. However Semelab assumes no responsibility for any errors or omissions discovered in its use. Semelab encourages customers to verify that datasheets are current before placing orders.